

锂离子电池规格书

Specification For Lithium-ion Rechargeable Cell

电芯型号 : N18650CNP

Cell Type : N18650CNP

Document NO.	P/PR03/PB-D-N18650CNP-ZZ-H	Revised Date	2020-6-29
Version	A/00	Pages	分发号: 06813
Approved	Checked	Designed	
Yanbin Li	Xinke Sun	Zhengjie Wu	

Contents 目录

- 1 Preface前言
- 2 Definition定义
 - 2.1 Standard charge method 标准充电方式
 - 2.2 Standard discharge method 标准放电方式
 - 2.3 Nominal capacity 标称容量
- 3 Cell type and dimension电芯型号及尺寸
 - 3.1 Description and type 电芯说明及型号
 - 3.2 Cell dimension 电芯尺寸
- 4 Cell characteristics电池特性
- 5 Technical requirements技术要求
 - 5.1 Cell usage conditions 电池使用环境
 - 5.2 Cell testing conditions 电池实验环境
 - 5.3 Requirement of the testing equipment 测量仪表要求
 - 5.4 Electrochemical characteristics 电化学特性
 - 5.5 Environmental and safety characteristics环境适应性及安全性能
- 6 Package picture包装图片
- 7 Shipment出货
- 8 Warranty质量保证
- 9 Storage and shipment requirement存储及运输要求
- 10 Warning and cautions in handling the lithium-ion cell电池使用时警告事项及注意事项
- 11 The restriction of the use of hazardous substances有害物质控制要求
- 12 Contact information联系方式
- 13 Version history修订履历

Document NO.	P/PR03/PB-D-N18650CNP-ZZ-H	Version	A/00	Page	1 / 13
---------------------	----------------------------	----------------	------	-------------	--------

1 Preface 前言

This specification describes the type, dimension, performance, technical characteristics, warnings and cautions of the lithium-ion rechargeable cell. The specification only applies to N18650CNP cells supplied by Zhengzhou BAK Battery Co., Ltd.

本标准描述了圆柱型锂离子电池的型号、尺寸、特性、技术要求及注意事项。本标准仅适用于郑州比克电池有限公司生产的圆柱型 N18650CNP 锂离子电池。

2 Definition 定义

2.1 Standard charge method 标准充电方式

At 25 ± 2 °C, the cell is charged to 4.2 V under 1250 mA constant current, then charged under 4.2V constant voltage until the current tapers to 100mA .

在 25 ± 2 °C 下，电池以 1250 mA 恒流充电至 4.2 V 后，以 4.2 V 恒压充电至电流小于等于 100 mA 。

2.2 Standard discharge method 标准放电方式

At 25 ± 2 °C, the cell is discharged to 2.5 V under 500 mA constant current.

在 25 ± 2 °C 下，电池 500mA 恒流放电至 2.5 V。

2.3 Nominal capacity 标称容量

The cell nominal capacity, signed as Cap. and using mAh as unit, is obtained as per standard charge followed by standard discharge.

电池标称容量以 Cap. 表示，单位为毫安时（mAh），是指电池按标准充电方式充电后，按标准放电方式放电得到的容量。

3 Cell type and dimension 电芯型号及尺寸

3.1 Description and model 电芯说明及型号

Description: cylindrical Li-ion rechargeable cell

说明：圆柱型锂离子可再充电电池

Type: N18650CNP

型号：N18650CNP

3.2 Cell dimension 电芯尺寸

Cell physical dimension listed in Figure 1(Unit: mm), with tube.

Document NO.	P/PR03/PB-D-N18650CNP-ZZ-H	Version	A/00	Page	2 / 13
---------------------	----------------------------	----------------	------	-------------	--------

电芯尺寸示意图如图 1 所示（单位：mm），包含热缩膜。

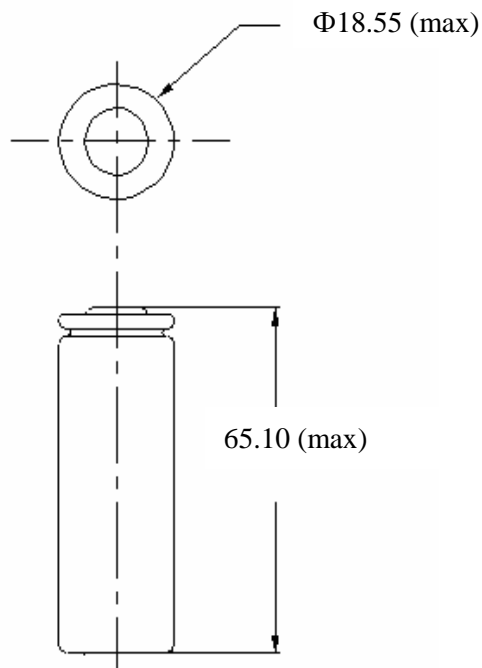

Figure 1/图 1

4 Cell characteristics 电池特性

Unless otherwise specified, the cell is fresh cell and tested by standard charge and standard discharge.
除非有特殊说明，否则所有样品均为新鲜电池，且按标准充电和标准放电方式进行测试。

ITEM 项目	SPECIFICATION 规格
Nominal capacity 标称容量	2500 mAh by standard charge / discharge 以标准充放电制式进行充放电，标称容量为 2500 mAh
Minimum capacity 最低容量	2400 mAh by standard charge / discharge 以标准充放电制式进行充放电，最低容量为 2400 mAh
Nominal voltage 标称电压	3.6 V
Charge cut-off voltage 充电截止电压	4.2 V
Discharge cut-off voltage 放电截止电压	2.5 V
Max continuous charge current 最大持续充电电流	4 A (25°C)
Max continuous discharge current 最大持续放电电流	30 A (25°C not for cycle life 不支持循环)

This spec. manual is the enterprise standard of Zhengzhou BAK Battery Co., Ltd. Without authorization, any pirate or circulation is prohibited.

本规格书为郑州比克电池有限公司企业标准，未经授权，禁止翻印、传播。

Document NO.	P/PR03/PB-D-N18650CNP-ZZ-H	Version	A/00	Page	3 / 13
---------------------	----------------------------	----------------	------	-------------	--------

Operating temperature (Cell surface) 工作温度 (电池表面温度) ①	Charge: 0 to 50 °C (Recommended recharge release ≤45 °C) 充电: 0 至 50 °C (再次重新充电电芯表面温度≤45 °C) Discharge: -20 to 75 °C (Recommended re-discharge release ≤50 °C) 放电: -20 to 75 °C (再次重新放电电芯表面温度≤50 °C)
Humidity range 湿度范围	0 ~ 60 % RH (Non-condensing) 0 ~ 60 % RH (不冷凝)
Internal resistance 内阻	≤ 16 mΩ (AC Impedance, 1000 Hz) 交流阻抗测量频率为 1000HZ, 交流内阻≤16 mΩ
Weight 重量	≤ 48.0g
①: The temperature specified above is the highest (lowest) temperature during the battery pack operation. ①: 上述所规定的温度即为电池包工作过程中最高 (低) 处的温度。	

5 Technical requirements 技术要求

5.1 Cell usage conditions 电池使用环境

Charge temperature (Cell surface): 0 ~ 50 °C (Recommended recharge release ≤ 45 °C)

充电温度 (电池表面): 0 ~ 50 °C (再次重新充电电芯表面温度≤45 °C)

Discharge temperature (Cell surface): -20 ~ 75 °C (Recommended re-discharge release ≤50 °C)

放电温度 (电池表面): -20 ~ 75 °C (再次重新放电电芯表面温度≤50 °C)

5.2 Cell testing conditions 电池试验环境

Unless otherwise specified, all tests stated should be done at 25 ± 2 °C.

除非有特殊说明, 所有测试须在 25 ± 2 °C 下完成。

5.3 Requirement of the testing equipment 测量仪表要求

The voltage measurement device: not less than 0.5 grade

电压测量装置: 不低于 0.5 级

The current measurement device: not less than 0.5 grade

电流测量装置: 不低于 0.5 级

AC Impedance: 1000 Hz

交流阻抗测量频率: 1000 Hz

Temperature meter: precision ≤ 0.5 °C

温度仪表要求: 精度为 ≤ 0.5 °C

Time measurement tolerance: ± 0.1 %

时间测量公差: ± 0.1 %

The size measurement tolerance: ± 0.1 %

尺寸测量公差: ± 0.1 %

Document NO.	P/PR03/PB-D-N18650CNP-ZZ-H	Version	A/00	Page	4 / 13
---------------------	----------------------------	----------------	------	-------------	--------

The quality measurement tolerance: $\pm 0.1\%$

质量测量公差: $\pm 0.1\%$

5.4 Electrochemical Characteristics 电化学性能

Unless otherwise specified, the cell should be fresh cell.

除非有特殊说明, 否则所有样品均为新鲜电池。

No. 序号	Item 测试项目	Test method and conditions 测试方法与条件	Criterion 性能标准												
5.4.1	Rate discharge capability 倍率放电性能	(1) Charge: At $25 \pm 2^\circ\text{C}$, 1.25A constant current charge to 4.2 V followed by 4.2V constant voltage charge to cut-off current 100 mA; (2) Discharge: 2.5A, 5A, 10A, 15A, 20A, constant current discharge to 2.5 V. (1) 充电: 在 $25 \pm 2^\circ\text{C}$ 下, 以 1.25A 恒流充电至 4.2 V 后, 以 4.2V 恒压充电至截止电流 100 mA ; (2) 放电: 以 2.5A, 5A, 10A, 15A, 20A, 恒流放电至 2.5 V。	<table border="1"> <thead> <tr> <th>Current 电流</th> <th>Relative Capacity 相对容量比</th> </tr> </thead> <tbody> <tr> <td>2.5A</td> <td>$\geq 95\%$</td> </tr> <tr> <td>5A</td> <td>$\geq 95\%$</td> </tr> <tr> <td>10A</td> <td>100%</td> </tr> <tr> <td>15A</td> <td>$\geq 95\%$</td> </tr> <tr> <td>20A</td> <td>$\geq 95\%$</td> </tr> </tbody> </table>	Current 电流	Relative Capacity 相对容量比	2.5A	$\geq 95\%$	5A	$\geq 95\%$	10A	100%	15A	$\geq 95\%$	20A	$\geq 95\%$
Current 电流	Relative Capacity 相对容量比														
2.5A	$\geq 95\%$														
5A	$\geq 95\%$														
10A	100%														
15A	$\geq 95\%$														
20A	$\geq 95\%$														
5.4.2	Rome temperature cycle life 常温循环寿命	(1) Charge: 4A constant current charge to 4.2 V followed by 4.2 V constant voltage charge to cut-off current: 100 mA, rest for 10 minutes; (2) Discharge: 20 A constant current discharge to cut-off voltage : 2.5 V (T-cut 75°C , re-discharge at 50°C).rest for 45 minutes. (1) 充电: 以 4A 恒流充电至 4.2 V 后, 以 4.2 V 恒压充电至截止电流 100 mA, 静置 10 分钟; (2) 放电: 以 20A 恒流放电至截止电压 2.5 V (温度大于 75°C 停止放电, 低于 50°C 再次放电), 静置 45 分钟。	Capacity $\geq 1750\text{mAh}$ after 301th cycles (70% of the standard capacity at $25 \pm 2^\circ\text{C}$) 循环第 301 圈电芯容量 $\geq 1750\text{mAh}$ ($25 \pm 2^\circ\text{C}$ 标准制式下容量的 70%)												

Document NO.	P/PR03/PB-D-N18650CNP-ZZ-H	Version	A/00	Page	5 /13
---------------------	----------------------------	----------------	------	-------------	-------

5.4.3	High-low temperature discharge performance 高低温放电性能	<p>(1) Charge: 1.25 A constant current charge to 4.2 V followed by 4.2 V constant voltage charge to cut-off current 100 mA, at 25±2 °C;</p> <p>(2) Discharge: 2.5A constant current discharge to 2.5 V at 60°C, 25°C, 0°C, -10°C, -20 °C.</p> <p>(1) 充电: 25±2°C下, 以 1.25A 恒流充电至 4.2 V 后, 以 4.2 V 恒压充电至截止电流 100 mA;</p> <p>(2) 放电: 在 60°C, 25°C, 0°C, -10°C, -20°C 下以 2.5 A 恒流放电至 2.5 V。</p>	<table border="1"> <thead> <tr> <th>Temperature 温度</th> <th>Relative Capacity 相对容量比</th> </tr> </thead> <tbody> <tr> <td>-20 °C</td> <td>≥60%</td> </tr> <tr> <td>-10 °C</td> <td>≥75%</td> </tr> <tr> <td>0 °C</td> <td>≥80%</td> </tr> <tr> <td>25 °C</td> <td>100%</td> </tr> <tr> <td>60 °C</td> <td>≥100%</td> </tr> </tbody> </table>	Temperature 温度	Relative Capacity 相对容量比	-20 °C	≥60%	-10 °C	≥75%	0 °C	≥80%	25 °C	100%	60 °C	≥100%
Temperature 温度	Relative Capacity 相对容量比														
-20 °C	≥60%														
-10 °C	≥75%														
0 °C	≥80%														
25 °C	100%														
60 °C	≥100%														
5.4.4	Storage performance 存储性能	<p>(1) Charge: 4A constant current charge to 4.2 V followed by 4.2 V constant voltage charge to cut-off current 100 mA; Discharge: 10A constant current discharge to 2.5 V, to obtain the initial capacity;</p> <p>(2) Charge: 4 A constant current charge to 4.2 V followed by 4.2 V constant voltage charge to cut-off current 100 mA;</p> <p>(3) Stored at 60±5°C for 28 days;</p> <p>(4) Discharge: 10A constant current discharge to 2.5 V;</p> <p>(5) Charge: 4A constant current charge to 4.2 V followed by 4.2 V constant voltage charge to cut-off current 100 mA; Discharge:10 A constant current discharge to 2.5 V, to obtain the recovery capacity.</p> <p>(1) 充电: 以 4 A 恒流充电至 4.2 V 后, 以 4.2 V 恒压充电至截止电流 100 mA; 放电: 以 10A 恒流放电至 2.5 V, 获得初始容量;</p> <p>(2) 充电: 以 4 A 恒流充电至 4.2 V 后, 以 4.2 V 恒压充电至截止电流 100 mA;</p> <p>(3) 于 60±5°C 下存储 28 天;</p> <p>(4) 放电: 以 10A 恒流放电至 2.5 V;</p> <p>(5) 充电: 以 4 A 恒流充电至 4.2 V 后, 以 4.2V 恒压充电至截止电流 100 mA; 放电: 以 10 A 恒流放电至 2.5 V, 获得恢复容量。</p>	<table border="1"> <thead> <tr> <th>Capacity 容量</th> <th>Relative Capacity 相对容量比</th> </tr> </thead> <tbody> <tr> <td>Recovery capacity 恢复容量</td> <td>≥90%</td> </tr> <tr> <td>Initial capacity 初始容量</td> <td>100%</td> </tr> </tbody> </table>	Capacity 容量	Relative Capacity 相对容量比	Recovery capacity 恢复容量	≥90%	Initial capacity 初始容量	100%						
Capacity 容量	Relative Capacity 相对容量比														
Recovery capacity 恢复容量	≥90%														
Initial capacity 初始容量	100%														

Document NO.	P/PR03/PB-D-N18650CNP-ZZ-H	Version	A/00	Page	6 / 13
---------------------	----------------------------	----------------	------	-------------	--------

5.5 Environmental and safety characteristics 环境适应性及安全性能

NO. 序号	ITEM 测试项目	CRITERION 性能标准	TESTING METHOD 测试条件与方法	ACCORDING 来源
5.5.1	Vibration test 振动测试	No leakage 不漏液	After standard fully charge, cell shall be attached to a vibration table directly and subjected to vibration that consists of 10 Hz to 55 Hz to 10 Hz at the speed of 1Hz/min in 90~100 mins.The total excursion of the vibration is 0.8 mm (0.060 inches). The cell shall be vibrated in each direction along axis of the cylinder and the vertical directions of axis of the cylinder. 将满电电芯放在振动实验台上，在 90~100 分钟内由 10 Hz 到 55 Hz 再到 10 Hz 以 1 Hz/min 的速率变化，振幅为 0.8 mm (0.060 英寸) 进行振动实验。电芯在电芯的轴向和与电芯轴向垂直的两个方向上振动。	UL1642
5.5.2	Drop test 跌落测试	No fire, No explosion 不起火，不爆炸	After standard fully charge, the cell is dropped three times from a height of 1.0 m onto a concrete floor, in random orientations, at 25±2℃ ;Observation of 1 h. 将电芯按标准充电方式充满电；25±2℃下，将电芯从 1.0m 高度处自由跌落 3 次到水泥地面上，方向随机；观察 1h。	IEC62133
5.5.3	Overcharge test 过充测试	No fire, No explosion 不起火，不爆炸	The cell is discharged following the standard discharge method. Apply a 8.4 V power supply and a 8 A charge current for 24 h. 电芯按照标准放电方式放完后，采用 8 A 电流 8.4V 电压持续充电 24 小时。	UN38.3
5.5.4	Forced discharge test 强制放电测试	No fire, No explosion 不起火，不爆炸	A standard discharged cell is subjected to a reverse charge at 2.5A for 90 min at 25±2℃ 电芯按照标准放电方式放电后，25±2℃条件下以 2.5A 反向充电 90 分钟。	IEC62133
5.5.5	130℃ hot oven test 130℃热箱测试	No fire, No explosion 不起火，不爆炸	After standard fully charge, the cell is put in the oven. And then the oven temperature will be ramped at 5℃ per minute to 130℃ and held at 130℃. When the temperature of the cell reach 130℃, the cell is maintained in the 130℃ oven for a maximum of 30 minute or until a fire or explosion is obtained, whichever comes first. Record the time that the cell temperature reaches 130℃ and the time when a fire or	GB31241

This spec. manual is the enterprise standard of Zhengzhou BAK Battery Co., Ltd. Without authorization, any pirate or circulation is prohibited.

本规格书为郑州比克电池有限公司企业标准，未经授权，禁止翻印、传播。

Document NO.	P/PR03/PB-D-N18650CNP-ZZ-H	Version	A/00	Page	7 / 13
---------------------	----------------------------	----------------	------	-------------	--------

			explosion occurs. 电芯按照标准充电方式充满电后，将电芯放进热箱里，然后将热箱按 5℃/min 升温到 130℃，当电芯的温度也达到 130℃时，电芯在热箱 130℃环境下保持 30 分钟或者电芯起火爆炸为止。记录电芯温度升至 130℃起直到电芯起火或爆炸的时间。	
5.5.6	Crush test 挤压测试	No fire、No explosion 不起火、不爆炸	After standard fully charge, the cell shall be crushed between two flat surfaces. The direction of the crushing force shall be vertical to axis of the cylinder. The crushing force is to be applied by a hydraulic ram with a 32 mm diameter piston. Crushing force is approximately 13 KN. Once the maximum pressure has been obtained it is to be released. 电芯按照标准充电方式充满电后，放在两个平整的表面进行挤压测试，压力器必须施加一个与圆柱电芯轴向垂直的力，平压于电芯。采用 32 mm 直径的液压活塞，所用压力为 13 KN，一旦达到最大压力值，即释放压力。	UL1642
5.5.7	Short circuit test at 25 ± 2℃ 25 ± 2℃短路测试	No fire、No explosion 不起火、不爆炸	After standard fully charge, the cell is to be short-circuited by connecting the positive and negative terminals of the cell with copper wire having a maximum resistance load of 80 ± 20mΩ. This test is done at room temperature. Monitor the cell temperature while testing. The battery is to discharge until a fire or explosion is obtained, or until it has reached a completely discharged state of less than 0.2 V and the battery case temperature has returned to ±10℃ of ambient temperature. 电芯按照标准充电方式充满电后，在室温下用铜线连接其正负极(线路总电阻 80 ± 20mΩ) 进行短路实验，实验过程中监视电芯温度变化，当电芯起火或爆炸，或达到完全放电状态(电压 < 0.2V)且温度下降到环境温度 ± 10° C 时，结束实验。	UL1642
5.5.8	Short circuit test at 55 ± 5℃ 55 ± 5℃短路测试	No fire, no explosion 不起火、不爆炸	After standard fully charge, the cell is to be short-circuited by connecting the positive and negative terminals of the cell with copper wire having a maximum resistance load of 80 ± 20mΩ. This test is done at 55 ± 5℃. Monitor the cell temperature while testing. The battery is to discharge until a fire or explosion is obtained, or until it has reached a completely discharged state of less than 0.2 V and the battery case temperature has returned to ±10℃ of ambient	UL1642

This spec. manual is the enterprise standard of Zhengzhou BAK Battery Co., Ltd. Without authorization, any pirate or circulation is prohibited.

本规格书为郑州比克电池有限公司企业标准，未经授权，禁止翻印、传播。

Document NO.	P/PR03/PB-D-N18650CNP-ZZ-H	Version	A/00	Page	8 / 13
---------------------	----------------------------	----------------	------	-------------	--------

			temperature. 电芯按照标准充电方式充满电后，在 $55 \pm 5^\circ\text{C}$ 下，用铜线连接其正负极(线路总电阻 $80 \pm 20\text{m}\Omega$) 进行短路实验，实验过程中监视电芯温度变化。当电芯起火或爆炸，或达到完全放电状态(电压 $< 0.2\text{V}$)且温度下降到环境温度 $\pm 10^\circ\text{C}$ 时，结束实验。	
5.5.9	Low pressure test 低气压测试	No leakage, no fire and no explosion, the maximum mass loss $\leq 0.1\%$ 不漏液、不起火、不爆炸，最大质量损失 $\leq 0.1\%$	After standard fully charge, the cell is to be stored at a pressure of 11.6 kPa or less for at least six hours at ambient temperature ($25 \pm 2^\circ\text{C}$). 电芯按照标准充电方式充满电后，在气压低于或等于 11.6 kPa 的常温 ($25 \pm 2^\circ\text{C}$) 条件下存储至少 6 h。	UL1642
5.5.10	Thermal cycling 温度循环	No fire, no explosion, no leak 不起火、不爆炸、不漏液	The standard fully charged cells are to be placed in a test chamber and subjected to the following cycles:(1) Raising the chamber-temperature to $70 \pm 3^\circ\text{C}$ within 30 min and maintaining this temperature for 4 h. (2) Reducing the chamber temperature to $20 \pm 3^\circ\text{C}$ within 30 min and maintaining this temperature for 2 h. (3) Reducing the chamber temperature to minus $40 \pm 3^\circ\text{C}$ within 30 min and maintaining this temperature for 4 h. (4) Raising the chamber temperature to $20 \pm 3^\circ\text{C}$ within 30 min. (5) Repeating the sequence for a further 9 cycles. (6) After the 10th cycle, storing the cells for a minimum of 24 h, at a temperature of $25 \pm 2^\circ\text{C}$ prior to examination. 电芯按照标准充电方式充满电后，放入测试箱内，按如下方式测试： (1) 30 分钟内升温至 $70 \pm 3^\circ\text{C}$ ，保持 4h; (2) 30 分钟内降温至 $20 \pm 3^\circ\text{C}$ ，保持 2h; (3) 30 分钟内降温至 $-40 \pm 3^\circ\text{C}$ ，保持 4h; (4) 30 分钟内升温至 $20 \pm 3^\circ\text{C}$; (5) 重复以上步骤 9 次; (6) 10 次循环后，在 $25 \pm 2^\circ\text{C}$ 下观察电芯至少 24h。	UL1642
Note 备注	All above safety tests will be conducted at $25 \pm 2^\circ\text{C}$ except where specified differently. Use proper ventilation with protective equipment. 除特殊说明，以上所有安全测试均应在 $25 \pm 2^\circ\text{C}$ 通风橱中，且附带有保护装置条件下进行。			

Document NO.	P/PR03/PB-D-N18650CNP-ZZ-H	Version	A/00	Page	9 /13
---------------------	----------------------------	----------------	------	-------------	-------

6 Package picture 包装图片



Small box
小箱

Big box
大箱

Pallet
货板

(100pcs cells in a small box, 2 small boxes in a big box)
(每小箱装 100 只电芯, 1 个大箱装 2 个小箱)

7 Shipment 出货

The cell shall be shipped in voltage range of 3.5 ~ 3.8 V or in accordance with customers' requirement. The remaining capacity before charging shall be changed depending on the storage time and conditions.

单体电池按 3.5 ~ 3.8 V 的充电电压或客户要求出货, 电池出货后充电前的剩余容量取决于储存时间和条件。

8 Warranty 质量保证

The cell warranty period is made according to business contract. BAK will replace no cells for free after shipment if there are problems due to customers' abuse or misuse instead of BAK's manufacturing failure.

电池的保质期依合同而定, 交货之后, 如非比克电池有限公司的制程原因, 而是客户的滥用和误用造成的电池质量问题, 比克电池有限公司不承诺免费更换。

BAK will not be responsible for the trouble caused by handling in violation of cautions in instructions.

比克电池有限公司对违反安全守则操作所产生的问题不承担任何责任。

BAK will not be responsible for the trouble caused by matching electric circuit, battery pack and charger.

比克电池有限公司对与电路、电池组和充电器搭配使用所产生的问题不承担任何责任。

BAK will not be responsible for any defect of cells caused during assembling after acceptance.

出货后客户在电池组装过程中产生的不良电池不在比克电池有限公司质量保证的范围之列。

9 Storage and shipment requirement 存储及运输要求

Item 项目	Conditions 环境	Permissible time 允许时间
-------------------	-------------------------	---------------------------------

This spec. manual is the enterprise standard of Zhengzhou BAK Battery Co., Ltd. Without authorization, any pirate or circulation is prohibited.

本规格书为郑州比克电池有限公司企业标准, 未经授权, 禁止翻印、传播。

Document NO.	P/PR03/PB-D-N18650CNP-ZZ-H	Version	A/00	Page	10 /13
---------------------	----------------------------	----------------	------	-------------	--------

Storage environment 储存环境	-20 °C ~ 60 °C, 60% RH Max	Less than 1 month 少于 1 个月
	-20 °C ~ 45 °C, 60% RH Max	Less than 3 months 少于 3 个月
	-20 °C ~ 25 °C, 60% RH Max	Less than 1 year 少于 1 年
About long time storage: If the cell needs to be stored for a long time, the cell's storage voltage should be 3.5 ~ 3.8 V. Also, it is recommended to charge the cell every six months. 关于长期存储: 若电池需长期存储, 电池的存储电压应该为 3.5 ~ 3.8 V。同时, 建议每 6 个月对电池进行充电。		

10 Warning and cautions in handling the lithium-ion cell 电池使用时警告事项及注意事项

Cell abuse can cause damage to the cell and/or personal injury. Please read and observe the standard cell precautions below before utilization.

电池滥用可能会造成对电池的损害或对人身伤害, 在使用前, 请仔细阅读以下安全守则。

Note 1, the customer is required to contact BAK Battery Co., Ltd. in advance, if and when the customer needs other applications or operating conditions not described in this specification.

注释 1, 客户如需在本规格书所述之外的条件下使用电池, 请提前联系比克电池有限公司。

Note 2, BAK Battery Co., Ltd. will take no responsibility for any accident when the cell is used under other conditions not described in this specification.

注释 2, 如在本规格书所述条件之外使用电池而发生事故, 比克电池有限公司不承担任何责任。

Warnings 警告

To prevent damage or injury from cell leaking, heating and/or explosion, please observe the following precautions before use. (It should be indicated especially in manual or instruction for users.)

为避免因电池泄漏、发热和/或爆炸造成伤害, 请在使用前注意以下预防措施。(应在使用说明手册或说明书中特别注明)

1	Do not use and leave the cell near a heat source such as fire or heater. 禁止在火、加热器待高温热源附近使用和留置电池。
2	Do not use or leave the cell under the blazing sun (or in heated car by sunshine). 不要将电芯放置在太阳光直射的地方。
3	Do not use or leave the cell at very high temperature conditions (e.g., strong direct sunlight or a vehicle in extremely hot conditions). Otherwise, it can overheat or catch fire or its performance will be degenerate and its service life will be decreased. 禁止在高温下(直热的阳光下或很热的汽车中)使用或留置电池, 否则可能会引起电池过热、起火、功能失效和寿命减短。
4	Do not short circuit, overcharge or over-discharge the cell.

This spec. manual is the enterprise standard of Zhengzhou BAK Battery Co., Ltd. Without authorization, any pirate or circulation is prohibited.

本规格书为郑州比克电池有限公司企业标准, 未经授权, 禁止翻印、传播。

Document NO.	P/PR03/PB-D-N18650CNP-ZZ-H	Version	A/00	Page	11 /13
--------------	----------------------------	---------	------	------	--------

	不要将电池短路、过充或过放。
5	Don't immerse the cell in water and seawater. Please put it in cool and dry environment if no using. 严禁将电池浸入海水或水中，保存不用时，应放置在阴凉干燥的环境中。
6	Don't reverse the positive and negative terminals. 严禁颠倒正负极使用电池。
7	Do not disassemble or modify the cell. 不要拆卸或修整电池。
8	Do not transport or store the cell together with metal objects such as necklaces, hairpins, coins, etc. 禁止将电池与金属，如发夹、项链等一起运输或贮存。
9	Make sure the cell is not with conspicuous damage or deformation. 不要使电池受到明显的损害或变形。
10	Don't connect the cell to an electrical outlet directly. 严禁将电池直接插入电源插座。
11	If the cell leaks and the electrolyte splashes into the eyes, rinse the eyes with clean running water immediately for at least 15 minutes, and go to hospital for treatment if necessary. 如果电池发生泄露，电解液进入眼睛，请立即用流动的清水冲洗眼睛至少 15 min，必要时请立即前往医院接受治疗。
12	Mixed use of cells of different types is not allowed. 禁止与液态锂离子或不同型号的锂电池混合使用。
13	Keep the cell away from babies. 避免让小孩接触电池。
14	Do not directly solder the cell and pierce the cell with a nail or other sharp objects. 禁止直接焊接电池和用钉子或其它利器刺穿电池。
15	Do not strike, throw or trample the cell. 禁止敲击、抛掷或踩踏电池等。
16	Use the cell charger specifically for that purpose when charging. 请选用锂离子电池专用充电器进行充电。
17	Please separate cells of different electrochemical systems from one another when disposing of secondary cells. 二次电池处理时，请将电池和其他电化学体系的产品分开。
18	Clean the terminals with a dry cloth before use if the cell terminals are dirty. Otherwise power failure or charge failure may occur due to the poor connection with the instrument. 如果电池弄脏，使用前应用干布抹净，否则可能会导致接触不良功能失效。
19	Cells should be removed from the device or charger immediately and not used again if they are over heat, give off odor, discolor or deform, or appear abnormally in any way during use, charging and storage. 如果电池发出异味、发热、变色、变形，或在使用、贮存和充电过程中出现任何异常现象，立即将电池从装置或充电器中移离并停用。
20	The cell replacement shall be done only by either cell supplier or device supplier instead of the user. 更换电池应由电池供应商或设备供应商完成，用户不得自行更换。
21	Please tape the terminals to insulate cells before discarding them in case of fire and explosion. 废弃电池之前应用绝缘纸包住电极，以防起火、爆炸。
22	Do not use cells in strong electrostatic and magnetic occasions, otherwise, it can cause safety problems easily.

This spec. manual is the enterprise standard of Zhengzhou BAK Battery Co., Ltd. Without authorization, any pirate or circulation is prohibited.

本规格书为郑州比克电池有限公司企业标准，未经授权，禁止翻印、传播。

Document NO.	P/PR03/PB-D-N18650CNP-ZZ-H	Version	A/00	Page	12 /13
---------------------	----------------------------	----------------	------	-------------	--------

	禁止在强静电和强磁场的地方使用，否则易带来不安全的隐患。
23	Use of damaged cells is not permitted. 禁止使用已损坏的电池。
24	Make sure package designing will not cause cell damages. 电池外壳设计和包装禁止损伤电池。
25	Cell packing should be conducted strictly according to level range, any misuse of different levels should not be permitted. 电池配组时需严格按等级执行，不能跨等级成组。
26	Disassembling cells from pack or module is not permitted unless under the guidance of professional technicians. 严禁将电池从电池包或电池模组中拆卸，除非在专业技术人员的指导下进行。

11 The restriction of the use of hazardous substances 有害物质控制要求

This model of lithium-ion cell is in accordance with our company's request of "The hazardous substances and material management standard" or customer's requirements.

本型号锂离子电池符合本公司《有害物质与材料管理规范》要求或参照客户要求执行。

12 Contact information 联系方式

If you have any questions regarding the cell, please contact the following address:

如有疑问，请按以下地址联系：

1.ZHENGZHOU BAK BATTERY CO., Ltd

The intersection 300meters West of Zhongxin Road & BAK Avenue, Zhongmu Country, Zhengzhou City, Henan, China. ZIP: 451450

Contact phone number: 0371-62033101

郑州比克电池有限公司

郑州市中牟县中兴路与比克大道交叉口向西 300 米 邮编 451450

联系电话：0371-62033101

2. SHENZHEN BAK POWER BATTERY Co., Ltd

BAK Industrial Park on Kuichong Road, Dapeng District, Shenzhen. ZIP: 518119

Contact phone number: 0755-61886818

深圳市比克动力电池有限公司

深圳市大鹏新区葵涌街道比克工业园 邮编：518119

联系电话：0755-61886818

13 Version change record 修订履历

Version 版次	Change Content 修改内容	Page 页码	PIC 修改人	Date 修改日期
---------------	------------------------	------------	------------	--------------

Document NO.	P/PR03/PB-D-N18650CNP-ZZ-H	Version	A/00	Page	13 /13
---------------------	----------------------------	----------------	------	-------------	--------

A/00	First Edition 初版	All 全部	Zhengjie Wu	2020-4-14
A/01	1.修改 60±5℃高温存储，充放电电流	P5	Zhengjie Wu	2020-6-29